

# LibMAS 09.10/1

# Annex A

Second Edition: January 2017

## DETECTOR SEARCH

### Responsible National entity:

Libyan Mine Action Centre (LibMAC )  
mandated by the Ministry of Defence (MOD)

Contact: LibMAC Deputy Director  
[quality.assurance@lmac.gov.ly](mailto:quality.assurance@lmac.gov.ly)



### NOTE:

This document is current at the date shown on this page. The Libyan Mine Action Standards (LibMAS) are subject to regular revision, so users should ensure that they are using the latest version of each document in the standards. The most recent versions of LibMAS are the versions that are posted on the LibMAS pages of the LibMAC website [www.lmac.gov.ly](http://www.lmac.gov.ly)

### Copyright notice

This document has been written with reference to the International Mine Action Standards (IMAS).

In its current form, this document is © **LibMAC Libya 2017** – All rights reserved.

**Contents**

1. Introduction.....	3
2. Detector Testing.....	3
3. Detector Performance Test.....	3
4. Detector Confirmation Test.....	3
5. Marking.....	3
6. Visual Search.....	4
7. Detector Search.....	4
8. Example of Detector Search.....	5
9. Example of "Opening" a New Demining Lane.....	7

## 1. Introduction

- 1.1 This Annex details manual mine clearance using metal detectors which are normally operated by one person holding the detector in one hand (single handed operation).
- 1.2 The Annex should be read in conjunction with LibMAS 03.40/1 Detectors.

## 2. Detector Testing

- 2.1 The detector is assembled and calibrated in accordance with the manufacturer's manual.
- 2.2 The detector tests results determine the performance of the detector to locate the pertinent mine/ERW in accordance with the required clearance depth and results are used to decide the optimum distance to deploy the detector search head above the ground.
- 2.3 The maximum detector search height above the ground shall be determined by a performance test prior to using the detector for searching during demining operations.
- 2.4 The standard detector search height for manual mine clearance shall be detailed in the Mine Action Organisation SOP
- 2.5 In circumstances where the maximum search height is increased, i.e. based on a site specific detector test and risk assessment, then this shall be detailed in the site Implementation Plan (IP).
- 2.6 **All detector test results and amendments to the search height shall be recorded by the Mine Action Organisation for each operational site, and an increase to the search height must be approved by the LibMAC.**

## 3. Detector Performance Test

- 3.1 A performance test is conducted for each detector prior to the commencement of mine clearance operations to confirm that it is functioning correctly (i.e. in accordance with the manufacturer's manual) and capable of locating the pertinent target at the required clearance depth. If the detector fails to meet the required standard it shall not be used.
- 3.2 See LIBMAS 03.40/1 Detectors, for further details.

## 4. Detector Confirmation Test

- 4.1 After completing the performance a confirmation test should be performed, using the manufacturer's standard "test piece" or same test item to confirm the detector is functioning in accordance with the performance test.
- 4.2 See LIBMAS 03.40/1 Detectors, for further details.

## 5. Marking

- 5.1 Wooden posts or rocks shall be used for temporary marking when conducting manual mine clearance to ensure that administration and working areas are obvious and as an aid to safety.
- 5.2 Temporary and improvised markers shall be used to mark the location of detector signals, mines, ERW, trip wires, and other hazards.
- 5.3 It is the responsibility of the Mine Action Organisation to ensure that the demining site is accurately marked prior, during, and on suspension or completion of mine clearance operations.
- 5.4 See 10.20/1 Demining Site Marking Systems, for additional detail pertaining to marking.

## 6. Visual Search

- 6.1 Prior to conducting a detector search, a visual search of the uncleared area shall be conducted. As a minimum, the area where the manual search is to be performed shall be visually searched. The following should be considered when conducting the visual search:
- Tripwires, cords.
  - Producing fuzes, mines, ERW, booby-traps.
  - Disturbance to the ground.
  - Depressions, holes, mounds.
  - Suspicious objects (inconsistent to the surroundings).
  - Other mine/ERW indicators (packaging, components, animal remains).
- 6.2 The Deminers should carry sufficient marking materials, tools and a container should there be a requirement to remove safe ordnance and parts (i.e. Free From Explosive), pertinent metal objects, vegetation, etc. Additional marking materials, tools and equipment should be conveniently located in a clear area.

## 7. Detector Search

- 7.1 The base stick (B/S) is positioned on ground to the front of the Deminer **with** cord or tape attached. A length of cord/tape shall be attached to both sides, assisting the Deminer in maintaining the 1 metre wide clearance lane and ensuring that it is kept straight.
- 7.2 Bobbins or similar may be used to assist with the deployed of the cord/tape when the B/S is moved forward, or the cord may be attached to a picket/peg or wrapped around the B/S itself.
- 7.3 The Deminers shall deploy the detector to systematically search the ground for pertinent mines/ERW. The detector shall be swept at the maximum search height (i.e. depending on detector test results) across the 1 metre wide lane, a minimum of 10 cm and maximum of 50 cm to the sides.
- 7.4 The same ground shall be searched at least twice with the detector before it is considered as cleared.
- 7.5 The search pattern may depend on the type of detector used and in particular the dimensions of the search head and must incorporate overlaps of the searched and unclear area.
- 7.6 The detector search shall not exceed 50 cm forward from the B/S, shall be a minimum of 10 cm and maximum of 50 cm to the sides of the demining lane, and on completion of the search the B/S shall be moved forward to a distance of at least 10 cm less than that searched.
- 7.7 In circumstances where the distance searched is 20 cm or less, then the B/S shall be moved forward a maximum of half the distance searched

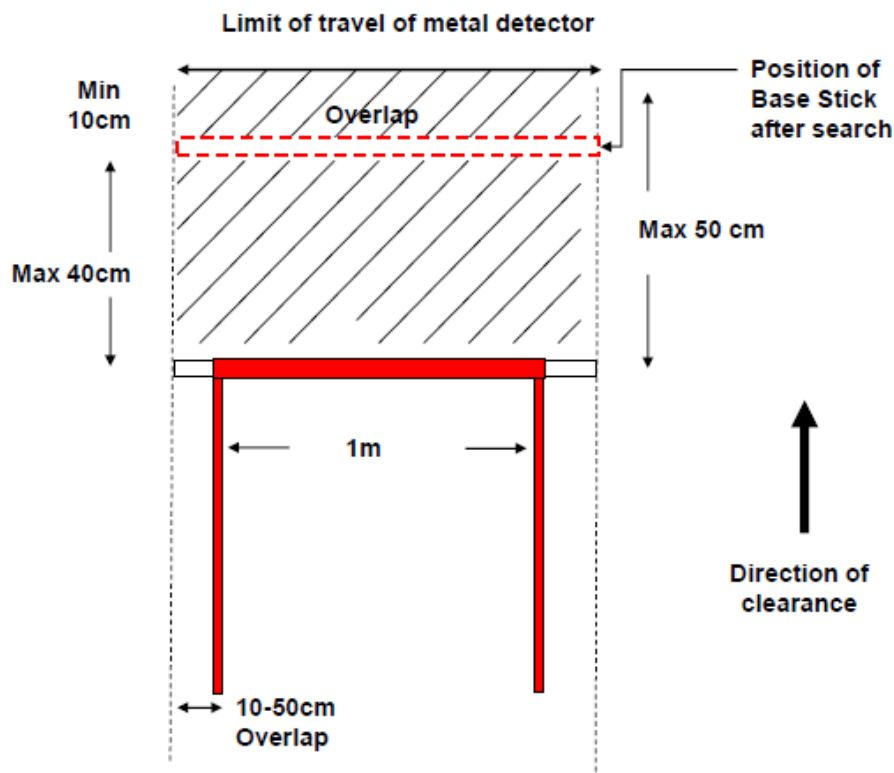

Figure 1: Detector Search– minimum requirements

## 8. Example of Detector Search

8.1 The following is an example of a proven detector search procedure:

- Start a minimum of 10 cm to the right or left side of the lane (i.e. depending on which hand the detector is held) and  $\frac{1}{2}$  a detector search head length forward from the B/S.
- Sweep the detector search head at a controlled speed across the lane twice (once in each direction), ensuring that the minimum overlap of 10 cm to the sides is achieved.
- On completion of the first 2 sweeps, move the detector search head  $\frac{1}{2}$  a head length forward to the next start position and repeat the search process.
- On completion of the second 2 sweeps, move the detector search head  $\frac{1}{2}$  a head length forward to the next start position and repeat the search process
- The detector search is now completed and in the event that no signals were indicated then the B/S may be moved forward 1 detector search head length (at least a distance of 10 cm less than that search).
- If detector signals were indicated then the Deminer shall identify, mark and investigate the source of the signals and re-confirm that the ground is clear, prior to moving the B/S forward.

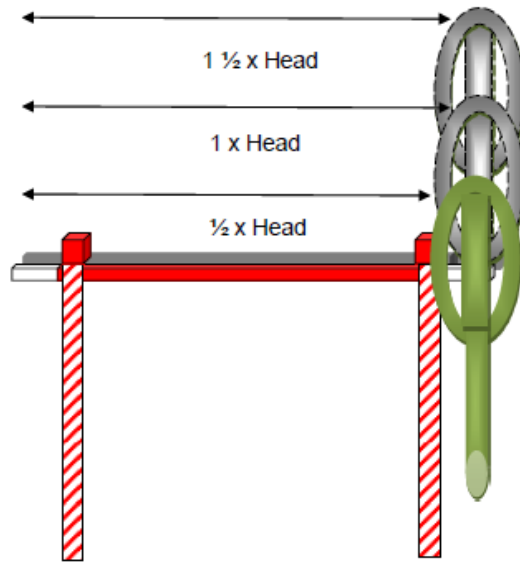

Figure 2: Example - Detector Search Pattern

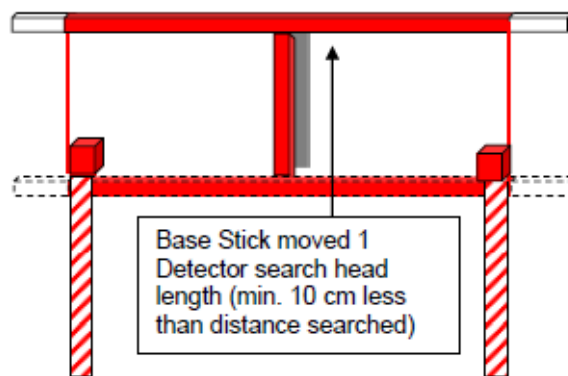

Figure 3: Moving the base stick after detector search

## 9. Example of “Opening” a New Demining Lane

9.1 When “opening” a new demining lane (i.e. from the start line), consideration shall be given when placing the B/S forward from the start line as the area may not have been searched with the detector.

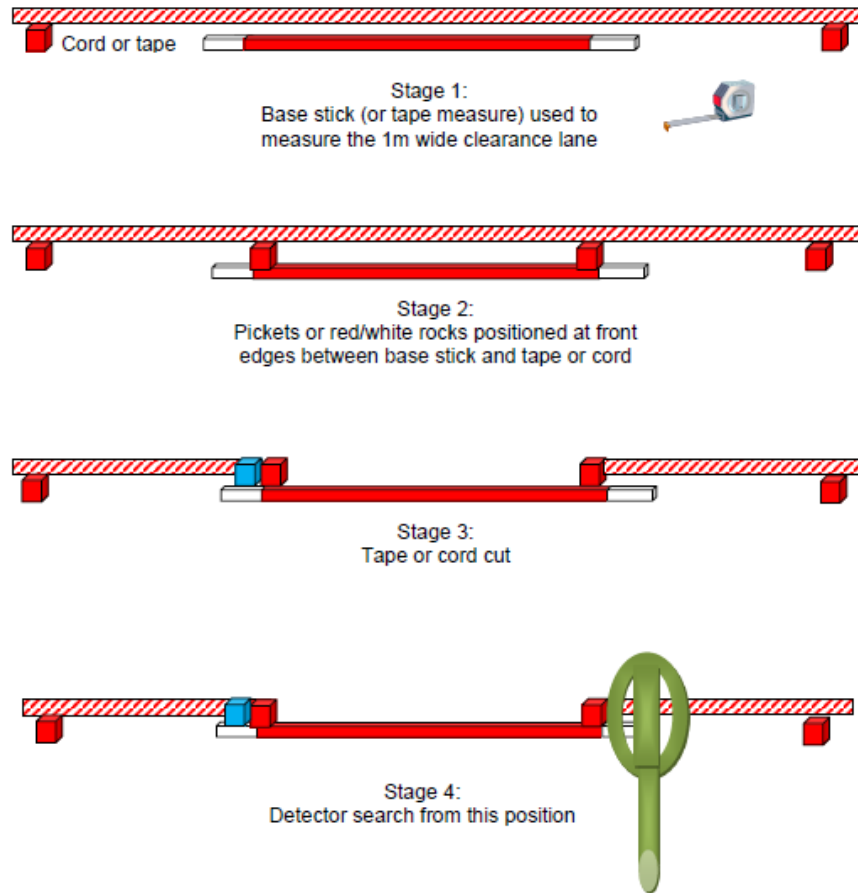

Figure 4: Opening a new demining lane